

TECHNOLOGICAL OFFER

The Pilot Line can be used to:

- Development of innovative and functional meltblown veils.
- Various possibilities for the optimization.
- Production trials with „difficult to process” polymers/nanocomposites.

COMPETITIVE PRODUCTS

- Advanced nonwovens.
- Light-weight structures.
- Reduced electrical resistivity.
- Compatibility with end user resins
- Wide range of areal weight.
- Easy & safe way to implement nanofillers to final product.

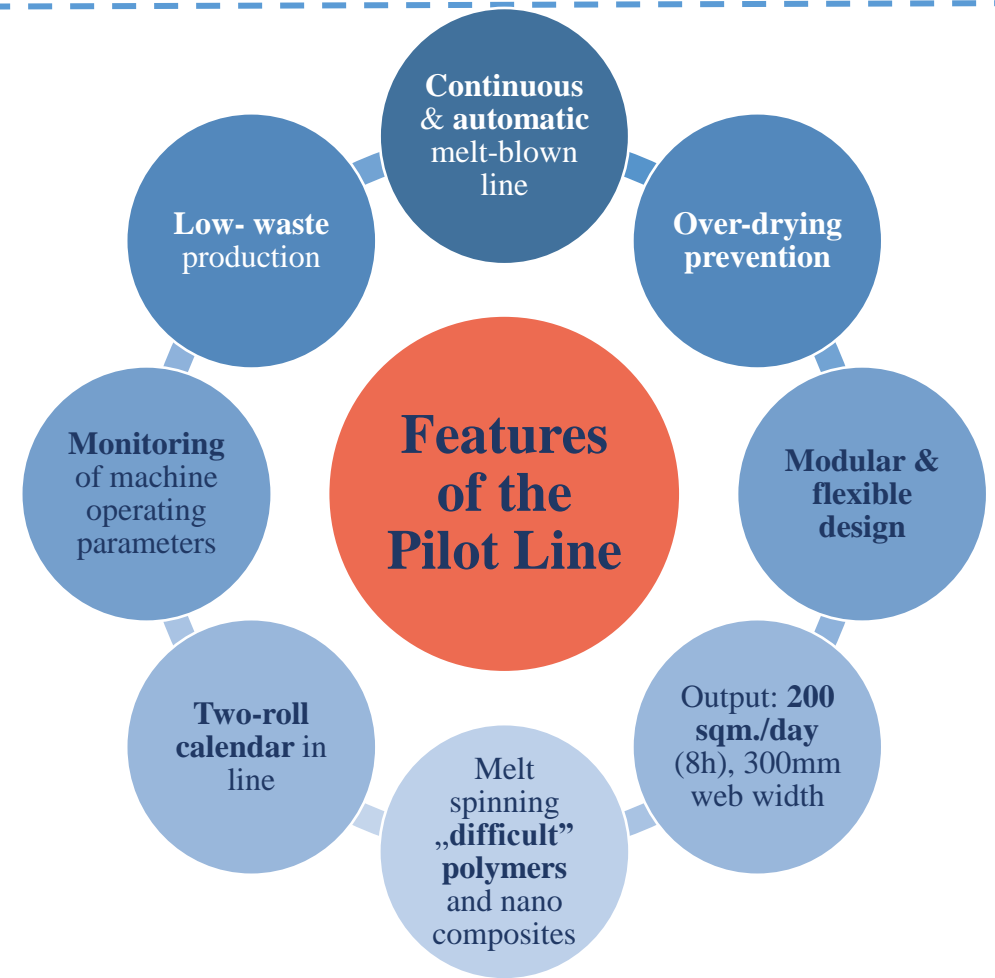
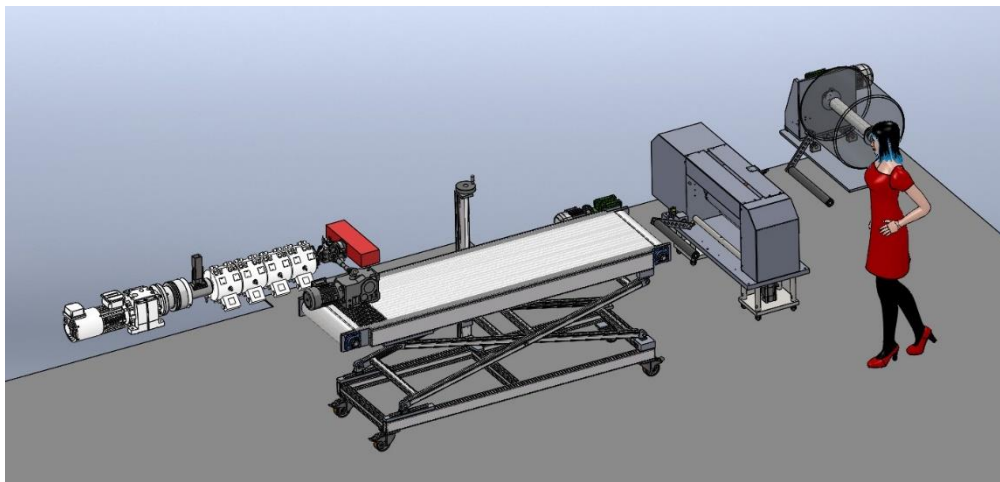

APPLICATIONS

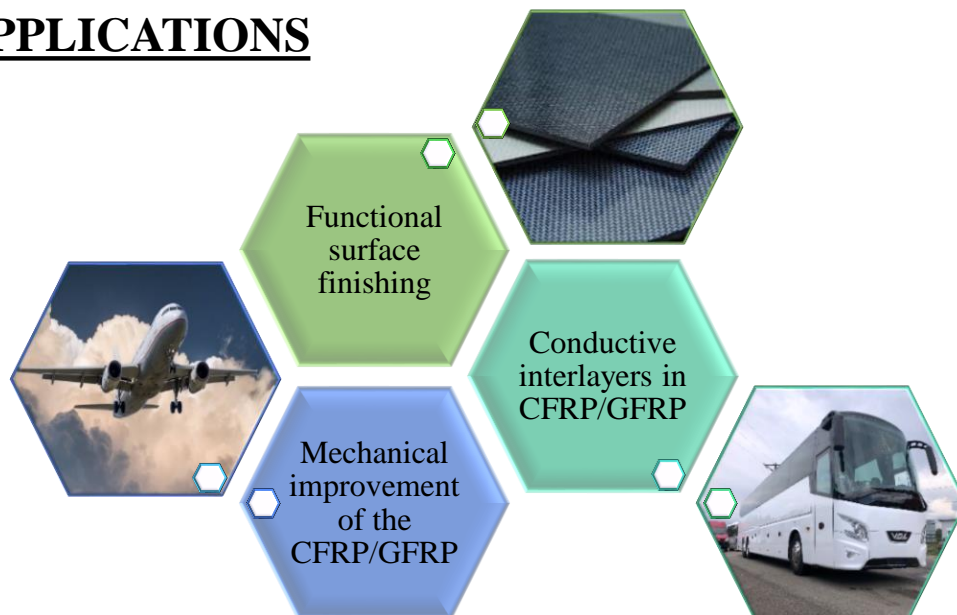

UPGRADED TECHNOLOGY

- High output consistency – improved proces stability.
- Reduced moisture absorption.
- Limited polymer degradation, upgraded die geometry.
- Continuous production with significantly less waste and a reduction in manual handling of the nonwoven fabric.
- On-line quality control system.

